



DAWSON
CONSTRUCTION PLANT LTD

SHEET PILE CAPPING SYSTEMS

INNOVATIVE
PILING
EQUIPMENT

HYDRAULIC PILING
HAMMERS

EXCAVATOR MOUNTED
VIBRATORS

EXCAVATOR MOUNTED
DRILLS

QUIET, VIBRATIONLESS
PUSH-PULL PILING

PILE EXTRACTION

SHEET PILE GUIDE
FRAMES

SHEET PILE
CAPPING SYSTEMS

CFA CLEANERS

PILE POINTS
& SPLICERS

HANDLING / LIFTING



**OPERATOR INSTRUCTIONS
& SPARE PARTS LIST**





DAWSON
CONSTRUCTION PLANT LTD

CONTACTS

WORLDWIDE
DEALER
NETWORK

GLOBAL
SUPPLY,
LOCAL
SUPPORT.

Dawson Construction Plant Ltd
Chesney Wold.
Bleak Hall,
Milton Keynes,
MK6 1NE, England
Tel: +44 (0) 1908 240300
Fax: +44 (0) 1908 240222

www.dcpuk.com

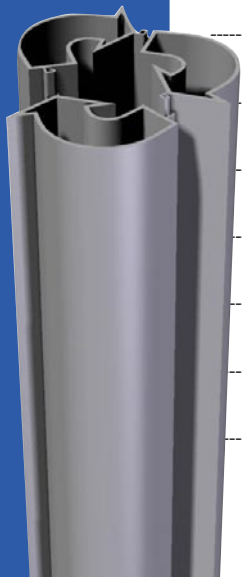



DAWSON
CONSTRUCTION PLANT LTD

CONTENTS

04	Capping System
06	Introduction The Redeb Support Bracket / The Multi-Pile Soffit Shutter Panel
09	Limitations of the Redeb Bracket Safe Working Load / Angle of Sheet Pile Web / Fixing width
10	Limitations of the Soffit Panels
11	Installation of the Redeb Support Bracket
12	Installation of the Soffit Panels
15	Removal of the Soffit Panels
16	Removal of the Redeb Support Bracket
17	Torque Wrench
18	Safety Points & Maintenance
21	Technical Specification
19	Location buttons
22	Component Parts Lists Soffit Panel (2.5m) / Redeb Bracket – RSB500 / 600 / 700
26	Redeb Bracket requirements for various sheet pile sections. Table 1 / Table 2
29	MDBS Redeb Support Bracket
37	Heavy Duty Capping



DAWSON
CONSTRUCTION PLANT LTD

CAPPING SYSTEM

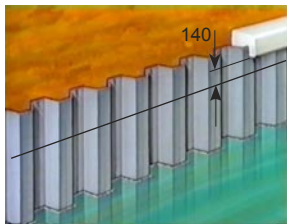

EXPOSED PILE SECTION
Scribe a setting out line for the RSB hard points 140mm below the bottom level of the cap.

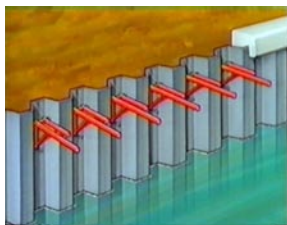

DAWSON'S REDEB SUPPORT BRACKET POSITIONED
Lower brackets into position.
Torque jacking bolts to 180Nm and level.

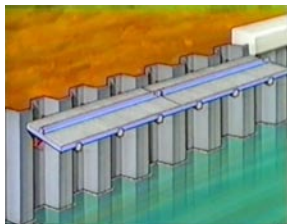

DAWSON SOFIT PANELS POSITIONED
Ensure at least 2 brackets support each panel. Lower the soffit panels into position with the front edge tight against the pile. Use timber wedges, to drive the panel forward against the sheet pile face then lift and lock guard rail. (not shown)



DAWSON
CONSTRUCTION PLANT LTD

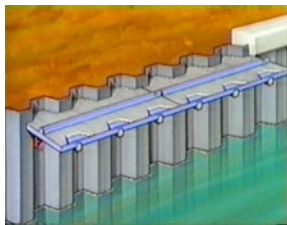

SOFIT BARS

Lightly tap ends of steel bars till they have push up hard against the contours of the sheet piles.

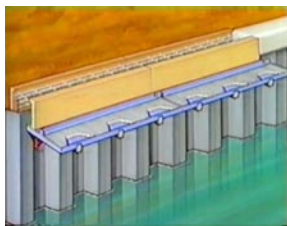

SHUTTERING

The side shutters can be positioned straight onto the soffit bars.

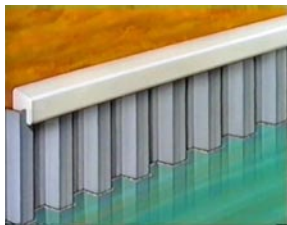

FINISH

Typically after 36 hours the soffit panels and redebs are ready to be removed.



DAWSON
CONSTRUCTION PLANT LTD

INTRODUCTION

The only purpose-made sheet pile capping system available is faster and more cost effective than any on-site 'lash ups'.

The Redeb Bracket and Soffit Panels can be assembled and re-used by unskilled labour. Welding or cutting of piles is not necessary. It renders obsolete the use of individual plywood soffit panels cut out to match pile pans.

Traditional 'old fashioned' methods use brackets welded against piles to carry longitudinal beams and shuttering timber. Such brackets have ultimately to be burned off, their stubs ground down and the piles paintwork made good.

All this trouble is avoided using this pile capping system.

Example

A concrete cap, approx. size 1.2m high by 0.9m wide and 275m in length was completed in four weeks. A 15 metre concrete pour was made every day. 5 no. per week using a total of 45 no. Redeb's and 18 no. 2.5m Panels (e.g. 3 no. 15 metre lengths).

The above resulted in a time saving of over 2 weeks compared with 'traditional' methods.

THE REDEB SUPPORT BRACKET

The Redeb Support Bracket provides a cheaper, simpler and faster method of supporting the soffit shutter for the construction of a concrete cap on "U" and "Z" shaped sheet piles.

The Redeb Support Bracket is a light yet robust piece of equipment designed to give many years of trouble free service providing it is correctly used and maintained. It is designed solely for use on steel sheet piles.



DAWSON
CONSTRUCTION PLANT LTD

Sheet piles are generally capped for Aesthetic purposes. The concrete cap serves to mask the inevitable irregularities in sheet pile length, penetration depth and line. They may also be used as a support for a railing or safety barrier.

There are three models of Redeb bracket - the RSB500, RSB600 and RSB700. The RSB500 & RSB600 models are designed to work on both 'Z' type and 'U' type sheet pile sections. The RSB500 covering narrower pile sections than the RSB600. The RSB700 is exclusively designed to work with the Hoesch Larssen 700mm wide 'U' piles and Arcelor 750mm wide 'U' piles. With these models most sheet pile sections can be accommodated within certain limitations.

THE MULTI PILE SOFFIT SHUTTER PANEL

There are two standard soffit shutter panels for all normal pile caps and a lot of abnormal ones as well.

Advantages

1. Very quick set up - saves time
2. Simple use for unskilled labour - saves money
3. Eliminates wastage of consumable materials - saves materials
4. Provides a formal system tried and proven as opposed to one off on-site lashups - saves money
5. Re-useable for all shapes of sheet pile usage - maximise repeat

The soffit shutter panel consists of rectangular rods which are retained within a framework. The rods are free to slide within set limits. With the panel secured on the Redeb Bracket the rectangular bars are pushed towards the sheet piles, starting from the deepest part of each pile. The bars will deck out the soffit area and assume the shape of the sheet piles including the distortion which occurs during driving.

The panels' structural members, which retain the decking bars, are capable of carrying normal loads when supported on Redeb Brackets at 'one-pair' of pile centres. No additional structural support is necessary. If in doubt please ask.

The panel will fit all known sheet piles and may also be used on continuous bored piles.

There are two lengths of panel, 2.5m and 3.0m. The 3.0m must be used for the 750mm wide pile sections (i.e. Arcelor AU type)

The panels are intended for mechanical handling, with the 2.5m weighing 360kg and the 3.0m panel weighing 430kg.





DAWSON
CONSTRUCTION PLANT LTD

LIMITATIONS OF THE REDEB BRACKET

Although the Redeb Support Bracket is suitable in the majority of pile cap situations there are certain limitations which must be taken into account before specifying the equipment for any given job. (If in doubt consult the manufacturer).

SAFE WORKING LOAD

The S.W.L. of the Redeb is specified in terms of a point load on the bracket at a certain location i.e. a load applied on the arms of the bracket at a distance of 310mm from the centre of the Hard Points. (see page 21 for technical specification)

- Bracket fixed on interlocks of 'U' type sheet piles - S.W.L. 2000 kgs.
- Bracket fixed on any inclined webs of 'U' or 'Z' type sheet piles having a minimum included angle of 55° - S.W.L. 1500 kgs.

This means that the maximum S.W.L. on any 'Z' (Frodingham) type sheet pile will be 1500 kgs.

ANGLE OF SHEET PILE WEB

The ideal fixing position for the Redeb bracket is between interlocks on a single 'U' type sheet pile. The interlocks are extremely rigid and the 'fixing face' is perpendicular to the steel hard points. However, in many cases the fixing face is at an angle to the hard point centre line. This occurs on 'Z' (Frodingham) type sheet piles and on narrow 'U' type sheets when the Redeb is too wide to fit between interlocks.

Under these conditions due consideration must be given to the angle involved and the choice of Hard Point type.

- The Redeb can not be used on sheet piles where the angle between the 'fixing face' (usually the web) and the Hard Point centre line is less than 55° .
- If this angle is between 55° and 65° then 70° Hard Points must be utilised.
- Where the angle is above 65° then standard 90° Hard Points should be used.

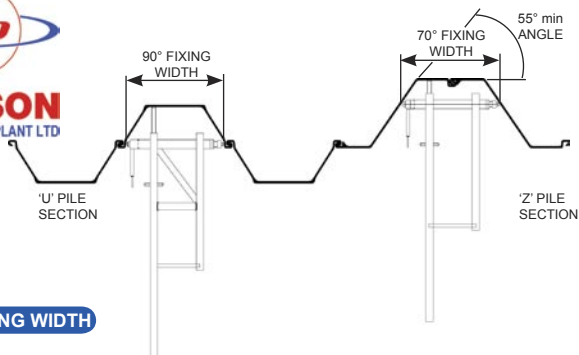

FIXING WIDTH

The 'Fixing Width' is the distance between Hard Point tips when installed on any given sheet pile(s). Each Redeb model has a minimum achievable and maximum allowable 'fixing width' and this is different in both cases depending on whether 70° or 90° Hard Points are used. The maximum allowable fixing width must not be exceeded as this will lead to bracket damage and possible system collapse.

THE JACKING BOLT SHOULD NEVER BE EXTENDED BY MORE THAN 77MM - MEASURE THE EXPOSED THREAD LENGTH IF IN DOUBT:-

Model	Fixing Width			
	70° Hard Point		90° Hard Point	
	Min	Max	Min	Max
RSB500	447	524	433	510
RSB600	532	609	518	595
RSB700	652	729	638	715

- Note: 1. There is a manufacturing tolerance on the above measurements of $\pm 3\text{mm}$.
2. For particularly tight profiles 'options' are available - see parts list.

LIMITATIONS OF MULTI PILE SOFFIT SHUTTER PANEL

It is essential that there are at least 2 redeb brackets supporting each soffit panel. For this reason when working with 750 wide pile sections (i.e. Arcelor AU type) a 3.0m panels must be used. It is acceptable to use 3.0m panels on all pile types, although when working on a radius a 2.5m panel may give better coverage.



DAWSON
CONSTRUCTION PLANT LTD

INSTALLATION OF THE REDEB SUPPORT BRACKET

1. Scribe a setting out line at the correct height on the pan of every pile. Using a centre punch, mark the Hard Point positions on this line. Allow a distance of 40mm from the Hard Point centres to the top surface of the bracket. Allow a distance of 100mm for the thickness of the soffit panel i.e. a total of 140mm.

Note:

a. To save time this marking out procedure need only be done on every alternative pile pan. Intermediate brackets can then be positioned later using the installed brackets for reference.

b. On sheet pile sections with particularly steep web angles it may be beneficial to drill a small hole in the pile instead of using a centre punch i.e. $\varnothing 4\text{mm}$ x 3mm deep using a cordless drill. This will ease installation considerably.

2. Lower the bracket into position and with the Quick Release mechanism in its extended position, with the release lever pointing downwards, unscrew the Jacking Bolt at the other end of the bracket with a torque wrench until the required torque is reached (180Nm). By doing this, the two steel Hard Points will be pressed into the sides of the piles.

3. The axis of the bracket is now at the correct level. The arms of the bracket have to be leveled by adjusting the Lower Adjusting Bolt at the base of the leg. Place a spirit level on a horizontal arm of the bracket to obtain the correct level.

4. Repeat this procedure until a bracket is correctly positioned in every alternate pile pan.

5. The intermediate brackets can now be positioned by leveling them up to a straight edge set between two previously positioned brackets.

6. Once all the brackets are secured, go back and check that they all have the correct torque. The brackets are now ready to receive the soffit shuttering.

INSTALLATION OF THE SOFFIT PANEL

- a. Position the Redebs as previously described in every outside pile pan. Ensure that they are at the correct level, correct torque (180 Newton metres) and horizontal (check with spirit level).
- b. Fix a 'back stop' inside the end of the longer arm of each Redeb Bracket and bolt it onto the Redeb using the M12 x 65 bolts and nuts provided.

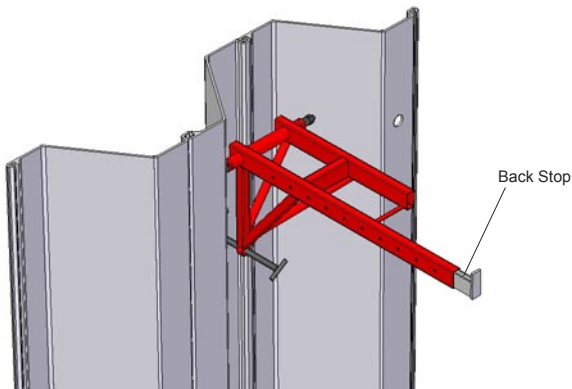



DAWSON
CONSTRUCTION PLANT LTD

c. Lower the Soffit Panels using a 3 leg sling/chain connected to the lifting points as shown below onto the Redebs. Ensure where possible, that the front edge of the panel is tight up against the outside edge of the sheet piles.

Ensure that at least 2 redebs are supporting each panel.

Next, ensure that the back stops are as close to the rear of the Soffit Panel as possible. (These back stops prevent the Soffit Panels moving back along the Redebs and take any horizontal load that may try to cause such a movement). Use timber wedges, to drive the panel forward against the sheet pile face, i.e. drive them between the back stop and the panel.

d. Bolt the Soffit Panels together with the fixing bolts provided (M20 x 60).

e. Lift and lock the in-built guard rail at the rear of the Soffit Panel.

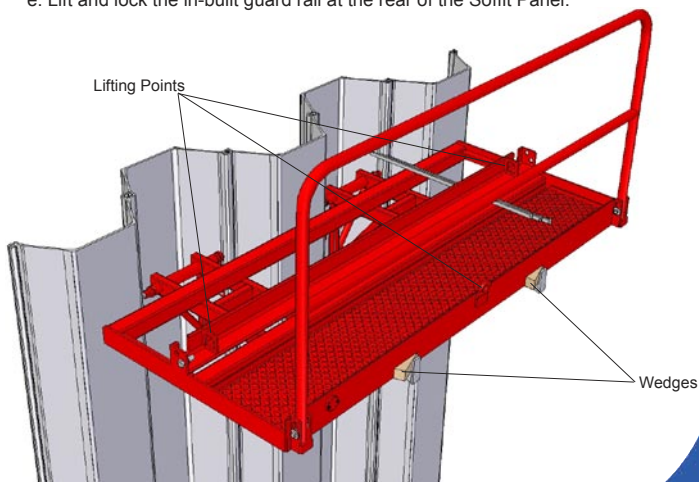



DAWSON
CONSTRUCTION PLANT LTD

f. Using a hammer, lightly tap on the ends of each of the steel bars, until they have all been pushed hard up against the sheet piles; start by tapping the bars into the centre of the pan of the piles and then work outwards. Oil the bars generously with shutter oil. Do not hit too hard as this will cause damage to the bar ends.

g. The side shutters can now be positioned straight on to the top of the Soffit Panel bars. The trapping bar member on the top side of the panel can be used to aid positioning of the side shutter.

However, the horizontal load exerted by the wet concrete should not be taken by the Panel, but by some other method, such as ties passing through the concrete and fixed to the sheet piles.

h. Any small gaps between the soffit bar ends and the sheet pile can be filled with Hessian or other filler plugs to prevent grout leakage.

i. Use shuttering or mold oil on the bars to minimise any adhesion from the concrete.

j. Cover the bars with plastic film to minimise concrete adhesion.

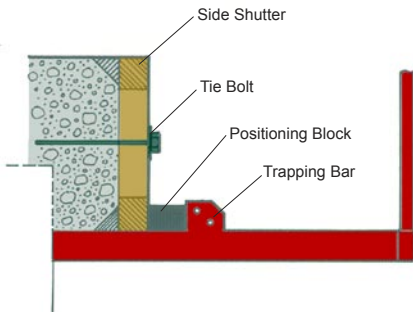

REMOVAL OF THE SOFFIT PANEL

After 36 hours the Soffit Panels and Redebs are ready to be stripped. From underneath the concrete cap, undo the levelling bolt on the Redeb a few turns to slightly tilt the Soffit Panel.

Connect the lifting chain to the lifting points (see panel assembly drawing at the rear of this manual) and ease the panel outwards.

The lifting of the Soffit Panel will automatically cause free movement of the steel bars, and will help to shed any grout. With a stiff brush sweep all concrete grout and debris off the bars to ensure no concrete becomes encrusted. The sooner the panels are scrubbed and cleaned after the concrete pour, the easier and quicker it is to prepare them for re-use. The panels will be supplied with as many bars in them as possible, which ensures a minimum of grout leakage between the bars. However, after a number of concrete pours, the free movement of the bars in the panel may become restricted and in practice this may be eased by removing one or two of the bars. Any 'gaps' caused by this will immediately be taken up by the remaining bars.

Walkways and safety rails are in an integral part of the 2.5m Soffit Panel.

Lifting points on the panels are provided for this sling as shown on the parts list.

Proper use of the sling with the two equal legs to the end of the panel and the third shorter leg to the centrally positioned chain at the rear should ensure that the panel remains level during setting up and stripping of the equipment.

N.B. Whilst stacking or unstacking panels into or out of the transportation stillage it may be an advantage to use only the end lifting points allowing the panel to tilt.



REMOVAL OF THE REDEB SUPPORT BRACKET

The cap rarely serves any structural purpose and as such it is generally accepted that the Redeb Support Bracket can be removed 36 hours after the concrete pour. Providing some cement had been used in the concrete, the concrete cap will certainly be strong enough to support itself after this time and enable the Redeb's and shuttering to be stripped! This saves time and money. To remove the bracket:-

1. Back off the tension on the Lower Adjusting Bolt to allow the bracket to tilt down at a slight angle. This will ease the removal of the soffit shuttering.
2. Having removed all shuttering, release some tension from the Jacking Bolt using a spanner. Secure the Redeb by some means, possibly a rope, then pull the Cam Release lever to retract the Cam Release mechanism. At this point the bracket will fall away from the sheet piles so pay attention to its movement and weight.
3. Having removed the bracket ensure it is cleaned, checked and lubricated before re-use as described under the maintenance section of these instructions.



DAWSON
CONSTRUCTION PLANT LTD

TORQUE WRENCH

It is important to use a torque wrench set to a reading of 180 Nm (Newton-metres) to tighten up the Jacking Bolt. This setting ensures the Redeb achieves its safe working load. In practice, to save time, an adjustable spanner may be used to initially tighten up the Jacking Bolt and the torque wrench used to achieve the final torque setting.

At the final torque setting there will be some localised deflection in the webs of the pile around the area where the hard points bite into the pile - this is to be expected. The hard points will bite into the steel by approximately 5mm.

Ensure the Jacking Bolt threads are in excellent condition at all times and that they are regularly lubricated. Failure to do so results in too much torque being 'absorbed' by the threads and the actual S.W.L. being reduced.



SAFETY POINTS & MAINTENANCE

- a. Ensure the correct torque of 180Nm has been imparted on the Jacking Bolt prior to applying any loading. This will ensure the relevant Safe Working Load has been achieved.
- b. Ensure there are at least 2 redeb brackets supporting each panel.
- c. Ensure that the Jacking bolt has not been extended by more than 77mm during installation. Check this by measuring the amount of exposed thread.
- d. Ensure the steel Hard Points are in good condition at all times. Any damage to these points necessitates immediate replacement. Damage includes 'chipping' or 'rounding' of the point. The point should not have a flat or rounding greater than 1.5mm.
- e. Keep the threads on the Jacking Bolt in good order by regular cleaning and greasing - at least after every pour. This also applies to the Cam Release Mechanism and Lower Adjusting Bolt. Failure to keep the Jacking Bolt well lubricated will lead to a reduced load carrying capacity for each bracket.
- f. Regularly check every Redeb bracket for damage or excessive wear on any item. The Safe Working Load of the bracket is dependent on all components being in tip-top condition. Damaged parts should not be used unless correctly repaired or replaced. If in doubt consult the manufacturer.
- g. Consecutive Redeb brackets must be installed at precisely the same level to ensure correct load distribution amongst all brackets for any given pour.
- h. When pouring concrete into the shuttering ensure that dynamic loading on the system is kept to a minimum i.e. do not pour from any height!

- i. Watch the angle between Hard Points and the sheet pile fixing face - follow the guidelines under the section headed 'Limitations of the Redeb Bracket'. Remember - this angle can decrease on radius walls!
- j. Ensure the soffit bars are kept clean and well lubricated with shuttering oil at all times.
- k. Replace any damaged or worn components immediately!
- l. The soffit panel should be held tight against the face of the sheet piles using the back stops provided and timber wedges.
- m. When removing soffit panels use only the lifting points provided and check the relevant joining bolts have been removed for adjacent panels.
- n. The soffit panel should always sit fully on the Redeb bracket and back stop. Do not allow the rear of the soffit panel to overlap the end of the long arm of the Redeb.
- o. Ensure all personnel are off the capping system and clear of the area underneath before the concrete pour commences.





DAWSON
CONSTRUCTION PLANT LTD

TECHNICAL SPECIFICATIONS

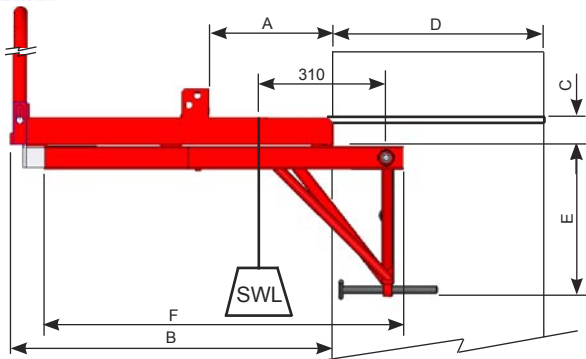

	PANEL SIZES			
	2.5M	3M	3M DEEP	HD
A	435	435	435	750
B	1130	1130	1330	2250
C	100	100	100	225
D	510	510	712	1300
PANEL WEIGHT	360kg	450kg	477.5kg	2000kg

	SUPPORT BRACKETS				
	RSB225	RSB500	RSB600	RSB700	HD
E	475	475	524	525	1840
F	705	1250	1250	1250	2690
WEIGHT	-	20kg	25.5kg	27.5kg	500kg



DAWSON
CONSTRUCTION PLANT LTD

	CAPPING SYSTEM				
	Z	Z +LOCATION BUTTON	U	MDBS	HD
SWL PER BRACKET	1500 kg	2000 kg	2000 kg	3000 kg	15,000 kg
MAX MASS INCLUDING PANEL, PER LINEAR METRE	1000 kg	1300 kg	1300 kg	2000 kg	10,000 kg

LOCATION BUTTONS

To be used on piles such as AZ17-700 and AZ13-770 which have angles too shallow to attach to standard system. Minimum included angle possible 40°, max angle 60°, see attached sketch. Also increase load carrying capacity to 2000kg on any type of Z pile.



Ø13mm

Part No.	871
----------	-----

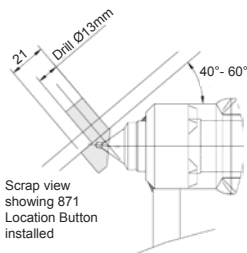

Scrap view
showing 871
Location Button
installed



DAWSON
CONSTRUCTION PLANT LTD

PARTS LIST

SOFFIT PANEL (2.5m / 3m / 3m Deep)

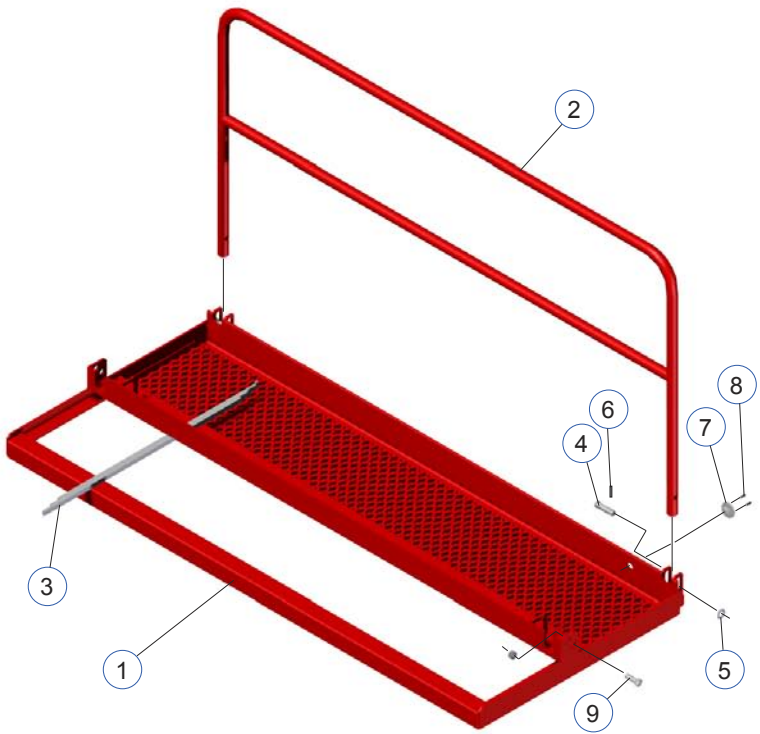



DAWSON
CONSTRUCTION PLANT LTD

			2.5m Soffit Panel	3m Soffit Panel	3m Deep Soffit Panel
Item	No. Off	Description	Part No.		
1	1	2.5m Soffit Panel Frame	701	721	725
2	1	Guard Rail	702		
3	248	Soffit Bar 1060 Long	703A		715
4	2	Pivot Pin	704		
5	2	Modified M24 Washer	705		
6	2	Ø3/16" x 1/2" long Split Pin	562		
7	1	Soffit Bar Plug	706		
8	2	M6 x 20 Long Caphead Screw	708		
9 (opt)	2	M20 x 60 Long Bolt c/w Nut	709		
10 (opt)	1	Special 3 Legged Sling	710		

OPTIONAL PARTS - For use with 2.5m Soffit Panels.

For joining panels:- Part No. 709 (Item 9)

For Soffit Panel Handling:- Part No. 710 (Item 10)



DAWSON
CONSTRUCTION PLANT LTD

PARTS LIST

REDEB SUPPORT BRACKET

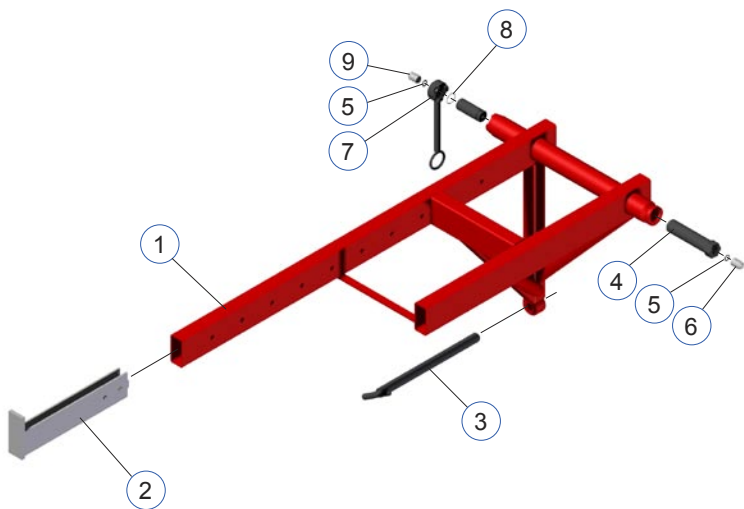



DAWSON
CONSTRUCTION PLANT LTD

Standard Redeb Support Bracket

Item	Description	No. Off	PART No.		
			500	600	700
1	Frame Assembly	1	800A	870A	845A
2	Long Back Stop	1	827		
3	Lower Adjusting Bolt	1	805A		
4	M33 Standard Jacking Bolt	1	810		
5	O-Ring - Hard Point	2	809		
6	Hard Point 70° For Jacking Bolt 810	1	828		
	Hard Point 90° For Jacking Bolt 810	1	808		
7	Cam Release Assembly	1	815A		
8	O-Ring Cam Release	1	811		
9	Hard Point 70° For Jacking Bolt	1	813		
	Hard Point 90° For Jacking Bolt	1	812		

Complete Assemblies

Part No.	Description
850A	Complete 500 Redeb Support Assembly
860A	Complete 600 Redeb Support Assembly
840A	Complete 700 Redeb Support Assembly



DAWSON
CONSTRUCTION PLANT LTD

PILE SECTIONS

Redeb bracket requirements
For British steel / corus sheet pile range

Pile Section	Bracket Type Required	Hard Point Type (°)	Maximum S.W.L. (kg)	Fixing Location / Comments
6W, 9W, 12W, 16W, 20W, 25W, 32W	500	90	2000	Install on Interlock
3, 4A, 6	500	90	1500	Install outside interlock
1BXN	Not Possible			Could use welded angle - check wth Dawson
1N	Not Possible			Could use welded angle - check wth Dawson
2N & 3N	500	70	1500	Install as deep into pan possible
4N	500	90	1500	Install as deep into pan possible
5	500	90	1500	1. Install with Cam release retracted. 2. Special min length 90° jacking bolt hard point. 3. Special jacking bolt required. 4. Install at an angle to C/L of approximately 20°/30°
LX8	600	90	2000	Watch Lower Adjusting bolt on pile corner
LX12, LX16, LX20, LX25, LX32	600	90	2000	Install on Interlock



DAWSON
CONSTRUCTION PLANT LTD

Redeb bracket requirements
For some overseas sheet pile sections

Pile Section	Bracket Type Required	Hard Point Type (°)	Maximum S.W.L. (kg)	Fixing Location / Comments
Arcelor AZ17,18,19,25, 26,28,34,36,38, 40,46,48,50 These piles are not the 700mm wide type pile.	600	70	1500	Install as deep into pan as possible
Arcelor AZ36-700 38-700, 40-700. These are all 700mm wide profiles.	700	70	1500	Install as deep into pan as possible Use 3.0mm soffit panels, not 2.5m
Hoesch Larssen 702, 703, 704	700	90 low head option	2000	Install on interlock Use 3.0m soffit panels, not 2.5m
Arcelor AU 14, 16, 17, 18, 20, 21, 23, 25, 26.	700	90	2000	Install on interlock Use 3.0m soffit panels, not 2.5m
Arcelor PU6, 8, 12, 18, 22, 25, 32	600	90	2000	Install on interlock.
Casteel CZ67-148 Syro SPZ13-26 Canadian MRM Z55-75	600	70	1000	Install as deep into pan as possible May experience difficulty achieving 180Nm torque on lighter sections
PZ27	600	70	1500	In some cases the RSB may be a tight fit into the pile pan i.e. point to point distance. If experiencing difficulty substitute the standard jacking bolt (810) for a special (831) and substitute hard points 828 for 834. Then substitute the cam release assembly 815A for special hard point 835.
PZ35, 40, PLZ23, 25	600	70	1500	Install as deep into pan as possible



DAWSON
CONSTRUCTION PLANT LTD

Redeb bracket requirements
For some overseas sheet pile sections

Pile Section	Bracket Type Required	Hard Point Type (°)	Maximum S.W.L. (kg)	Fixing Location / Comments
Casteel CS 55, 60, 76 Casteel CU110,116, 122	500	70	1000	May experience difficulty achieving 180Nm torque on lighter sections
Canadian MRM XZ85-100	600	70	1500	Install as deep into pan as possible.
Casteel CU 81, 99, 118	500	90° special on jacking bolt side and 90° standard on cam release side	1000	Substitute the standard jacking bolt (810) for a special (831) and use hard point 832.
AZ13, Hoesch 12, Bethlehem PZ22, Casteel CU94, 104, CL42/47/57 CMRM EZ80-95	<p style="text-align: center;">Not possible</p> <p style="text-align: center;">Where web angle causes this limitation it is possible to weld small pieces of angle iron to the pile webs so as to construct a suitable fixing face – details available on request.</p>			

MDBS REDEB SUPPORT BRACKETS



- TO BE USED WITH THE CURRENT REDEB SUPPORT BRACKETS.
- INCREASES CURRENT SYSTEM CAPACITY FROM 1500Kg TO 3000Kg.
- CAN BE USED FOR COMBINATION WALLS AND ON OUT PANS.
- REQUIRES A Ø53 HOLE TO BE CUT THROUGH PILE FACE 166mm BELOW BOTTOM FACE OF CAP.
- MAX THICKNESS OF PILE = 30mm
HEIGHT ADJUSTMENT +/- 11mm





DAWSON
CONSTRUCTION PLANT LTD

INSTALLATION

DIMPLE INDICATES
CAM LOCKED IN
POSITION.
SAFE TO POUR.

MDBS

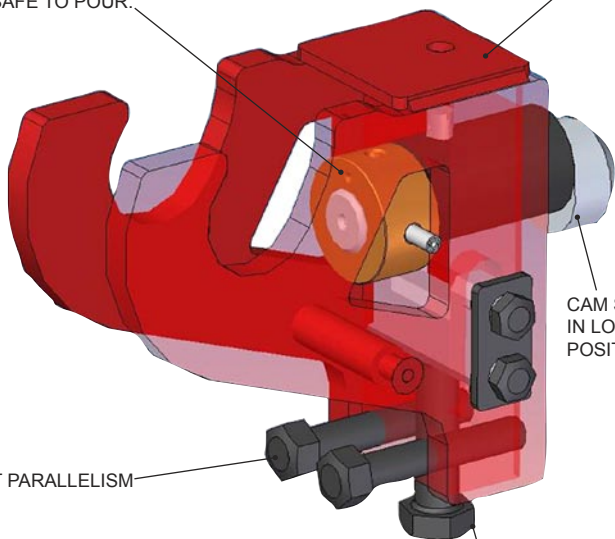

CAM SHOWN
IN LOCKED
POSITION

ADJUST PARALLELISM

+/- 11mm HEIGHT
ADJUST



DAWSON
CONSTRUCTION PLANT LTD

INCORRECT !

THE VERTICAL MEMBER OF THE RSB SHOULD LIE BETWEEN THE PLATES OF THE MDBS, ENSURE THE RSB LEVELLING SCREW IS IN LINE WITH THE MDBS CENTRE.

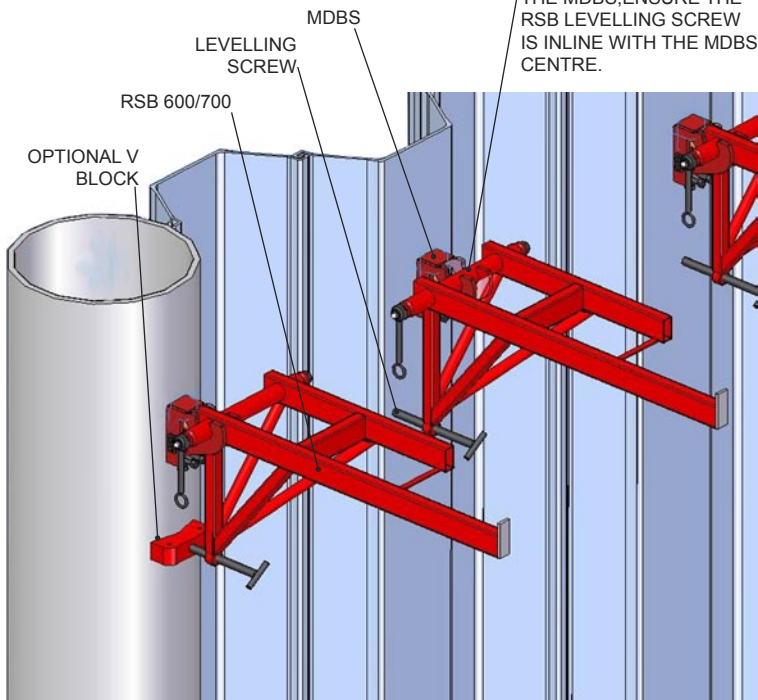



INSTALLATION OF THE MDBS REDEB SUPPORT BRACKET

1. Mark and cut a hole through the pile that the MDBS is to be hung from. The hole must be $\text{Ø}53 +3\text{mm}/-\text{Nil}$. The center of the hole is 166mm below the bottom face of the cap to be cast. Note the maximum thickness of the material must not exceed 30mm.
2. Insert the MDBS cam through pile and turn the handle/Boss 180 degrees until the cam is fully engaged. There is a small divot in the Boss which will now be in the uppermost position signifying the cam is in its locked position.
3. Lower the RSB600/700 bracket into the MDBS. The verticle member of the RSB should lie between the plates of the MDBS ensuring the RSB leveling screw is inline with the MDBS center. The round bar of the RSB should sit neatly into the MDBS cutouts.
4. If the axis of the bracket is not at the correct level then adjust the height of the RSB bracket using the MDBS +/-11mm vertical. adjusting screw. The arms of the bracket have to be leveled by adjusting the Lower Adjusting Bolt at the base of the leg. Place a spirit level on a horizontal arm of the bracket to obtain the correct level.
5. Repeat this procedure until all MDBS and RSB brackets are correctly positioned on every pile.
6. Do NOT use the hard points installed in the RSB brackets when using the MDBS support bracket.
7. It is possible to use a combination of MDBS + RSB in conjunction with RSB brackets installed in there normal manner as long as loadings permit. Please refer to the RSB procedure for the installation and maximum loadings.
8. Once all the brackets are secured, go back and check that they are all level, the cams are fully engaged "Divot uppermost" and if a combination has been used then the traditionally installed RSB must have the correct torque. The brackets are now ready to receive the soffit shuttering.

REMOVAL OF THE MDBS SUPPORT BRACKET

The cap rarely serves any structural purpose and as such it is generally accepted that the Redeb Support Bracket can be removed 36 hours after the concrete pour. Providing some cement had been used in the concrete, the concrete cap will certainly be strong enough to support itself after this time and enable the Redeb's and shuttering to be stripped! This saves time and money. To remove the bracket: -

1. Back off the tension on the Lower Adjusting Bolt to allow the bracket to tilt down at a slight angle. This will ease the removal of the soffit shuttering.
2. Having removed all shuttering, The RSB bracket can be removed from the MDBS by simply lifting it out.
3. Now the MDBS can be removed from the pile by turning the cam 180 degrees until the divot on the boss is in the lower position. The cam is now inline with the main shaft and can be extracted from the hole.
4. Having removed the MDBS and RSB bracket ensures they are cleaned, checked and lubricated before re-use as described under the maintenance section of these instructions.

V-BLOCK



To be used in conjunction with the M.D.B.S and R.S.B. Bracket. The V-Block locates over the end of the R.S.B. lower adjusting bolt preventing it from slipping off round tubular piles.

(See page 41 for assembly view)

Part No.	MDBS-028-01
----------	-------------

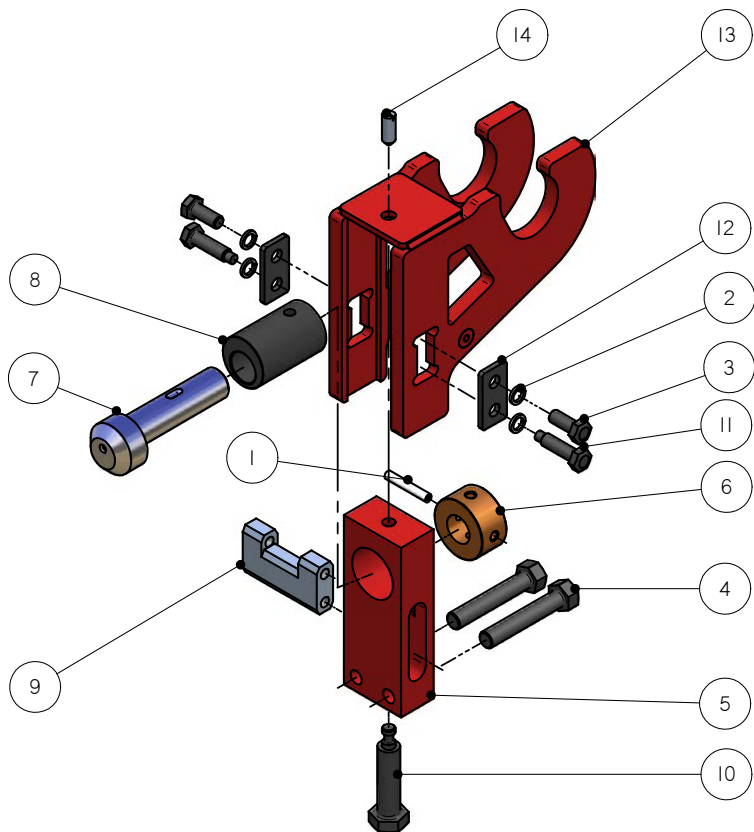

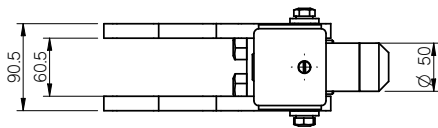

DRILL $\varnothing 4\text{MM} \times 2\text{MM}$ DEEP
MARK HERE WITH CAM IN THE
LOCKED DOWN POSITION
ON ASSEMBLY

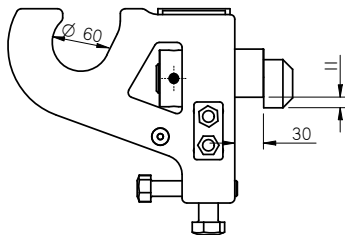
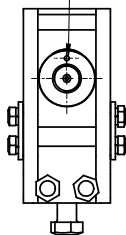

OTES: DRAWN MID POSITION WITH +/- 11MM OF VERTICAL ADJUSTMENT. WEIGHT 11.7Kg

14	1	SPRING PLUNGER	ST. STEEL	0.0 kg	MOBS-030-01
13	1	WELDED BRACKET		11.7 kg	MOBS-026-02
12	2	KEEPER PLATE	BS 4360 43A	0.0 kg	MOBS-025-06
11	2	MODIFIED HEX HD BOLT	OM12.050.01	0.0 kg	MOBS-024-06
10	1	MODIFIED HEX HD BOLT	OM20-090-01	0.0 kg	MOBS-022-01
9	1	JACKING SPACER BAR	080M40 En8	0.0 kg	MOBS-021-07
8	1	CAM COLLAR	EN36B	0.8 kg	MOBS-012-03
7	1	CAM	EN24T	1.0 kg	MOBS-010-03
6	1	LOCKING COLLAR	EN24T	0.5 kg	MOBS-008-03
5	1	MAIN BODY	BS 4360 43A	2.4 kg	MOBS-007-08
4	2	HEX HD BOLT		0.0 kg	OM16.090.04
3	2	HEX HD BOLT	ST. STEEL	0.1 kg	OM12.030.01
2	4	SPRING WASHER		0.0 kg	OM12-000-21
1	1	COILED SPRING PIN		0.0 kg	OM08.050.22
Ref.no.	Qty.	Part name	Material	Dimension	Remark



DAWSON
CONSTRUCTION PLANT LTD

HEAVY DUTY CAPPING SYSTEMS



- REDEB SUPPORT BRACKETS
- MULTI PILE SOFFIT PANELS
- SWL 10 TONNE PER METRE





DAWSON
CONSTRUCTION PLANT LTD

FEATURES

The multi pile soffit shutters have 148 individual adjustable bars which follow the pile wall contour and do away with the need for profiled plywood in fills. Concrete can then be poured directly on top of these bars.

The system is capable of carrying a maximum vertical load of 10 Tonnes per metre.

Maximum pile depth of 2 metres from pile face can be cast.

Redeb support brackets can be fitted onto flat or round pile faces. The brackets have been design with a minimum width of only 170mm.

To fit brackets only a single Ø85mm hole has to be cut through the pile face.

Redeb support brackets are secured to the pile face by means of a location cam which locates through the Ø85mm hole. The cam is then turned through 180° for quick installation and removal.

Each Redeb support bracket can be adjusted along its length after securing to pile for both height and angle to pile face. +/- 25mm
Built in safety hand rail.

WEIGHT AND DIMENSIONS

SOFFIT PANEL WEIGHT = 2000 Kg

SOFFIT PANEL DIMENSIONS = 3000 x 2250 x 380 mm

BRACKET WEIGHT = 500 Kg

BRACKET DIMENSIONS = 2850 x 1840 x 170 mm



DAWSON
CONSTRUCTION PLANT LTD

INSTALLATION

1. Before mounting the bracket, ensure it is in the SET position. **See Manual setting 1.** The amount of levelling once the bracket is located in the hole is limited to +/- 25mm.
2. Predetermine level for the location holes. With the bracket in its SET position the distance from the centre of the Ø85mm hole to the top face of the soffit panel bars = 456mm, (or 328mm when using standard lower capacity system) it is important that this is allowed for when cutting the holes in the pile face.
3. Scribe a level line along length of the pile face and burn through Ø85mm +5mm holes through piles ensuring there is clearance behind the pile to allow the cam to turn. Maximum pile thickness = 25mm.
4. To pick up the bracket use the lifting arm using a single sling (see removal for position).
5. Position the bracket so that its cam is completely through the pile. Push the "U" shaped handle forward. Next engage the cam drive boss with the cam locking boss and turn anti-clockwise through 180°. This will lock the bracket onto the pile face. **See manual setting 4**
6. Before removing the sling visually check that the bracket cam is correctly through pile.
7. Adjust the angle of the bracket initially using the lower jacking screw before the soffit shutter panel is placed on top. **See manual setting 2**
8. Pick up the soffit shutter panel ensuring all soffit bars are in there fully back position. Use the lifting points as indicated. **See manual setting 7**
9. Lower the soffit shutter panel carefully onto the support brackets.
10. Ensure that all the brackets are making contact with the soffit shutter by levelling using the front and rear jacks. The jacks are adjusted independently and can be set at different heights if angular adjustment is required.



DAWSON
CONSTRUCTION PLANT LTD

IMPORTANT NOTE: - THE BRACKET MUST NOT BE SET LOWER THAN THE LOWEST POSITION SHOWN ON THE DRAWING.

This is necessary because after casting the cap the bracket has to be lowered so the soffit panel can be removed. If the cap is cast with the bracket set at its lowest position there is no adjustment left to lower the bracket and remove the soffit panel.

11. Secure each panel using the clamping kits. **See manual setting 8**
12. Raise the soffit shutter panel safety rail and engage the lower portion of the safety rails in the corresponding sockets. **See manual setting 7**
13. Using a soft faced mallet lightly tap on the ends of each soffit bar until they have all been pushed up against the pile face. Start by tapping the bars into the centre of pan of piles and work outwards. Oil the bars generously with shutter oil. Do not hit the bars too hard as this will cause damage to the bar ends.
14. The side shuttering can now be positioned straight on the top of the soffit panel bars. The soffit bar trapping member can be used to aid positioning of the side shutter however the horizontal load exerted by the wet concrete must not be taken by the panel, but by some other method, such as ties passing through the concrete and fixed to both side shutters on either side of the sheet pile.
15. Any small gaps between the soffit bar ends and the sheet pile can be filled with Hessian or other filler plugs to prevent grout leakage.
16. Use shuttering or mould oil on the bars to minimise any adhesion from the concrete.
17. Cover the bars with plastic film to minimise concrete adhesion and reduce the ripple effect left by the bars if its an issue.

REMOVAL OF THE SOFFIT PANELS

Only after the concrete cap has sufficiently set enough to support its own weight can the process of stripping the panels from underneath the cap begin. Refer to architect drawings to determine the cure time of the concrete cap.

1. Loosen and remove clamping kits.
2. Lower bracket top members by turning front and rear jacks to the fully down position. This will create a minimum 25mm gap between the soffit panel and concrete cap.
3. Attach suitable lifting chains to the lifting points on the soffit panel.
4. The soffit panel can now be extracted.
5. The lifting of the soffit panel will cause free movement of the soffit bars, and will help shed any grout. With a stiff brush sweep all concrete grout and debris of the bars to ensure no concrete becomes encrusted. The sooner the panels are scrubbed and cleaned after the concrete pour, the easier and quicker it is to prepare them for re-use. A high pressure washer is also very good for cleaning the soffit bars.
6. Oil the bars and push them back into the panels. If after a number of pours it becomes difficult to push all the bars back, if this happens remove a bar through the soffit bar removal window. The remaining bars will immediately take up any gaps caused by this.



DAWSON
CONSTRUCTION PLANT LTD

REMOVAL OF THE REDEB SUPPORT BRACKET



Warning

Stand clear of
suspended load

The redeb support bracket can only be removed after the soffit shutter panel has been removed.

1. To remove the redeb support bracket use a suitable sling.
2. Position the sling between the last two braces as shown in picture below so that the bracket inclination will be slightly down at the front when removed from the location hole.
3. Turn the cam 180 degrees clockwise to disengage from the hole.



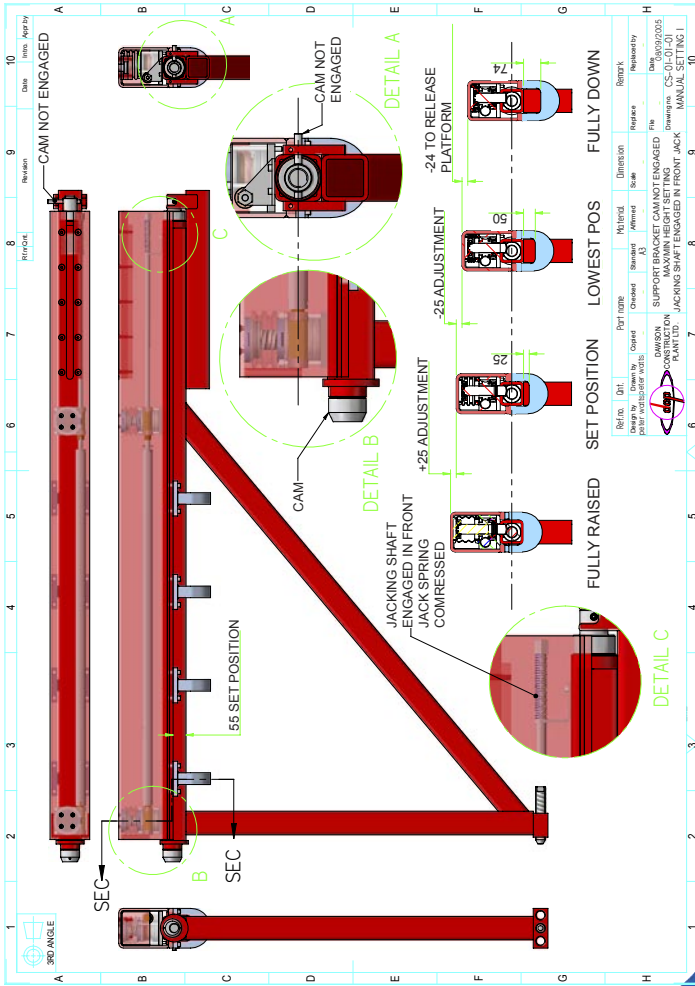

Ref. no.	QTY	Part name	Checked	Asst	Approved	Dimension	Remark
Design by	Drawn by	Engled	Checked	Asst	Approved	Scale	Required by
part no. w/total no. parts		DAMSON CONSTRUCTION PLANT LTD.		SUPPORT BRACKET CAM NOT ENGAGED		File	Date: 06/09/2005
				MAXIMUM HEIGHT SETTING		CS-01-01	Drawing no.
				JACKING SHAFT ENGAGED IN FRONT JACK		MANUAL SETTING I	

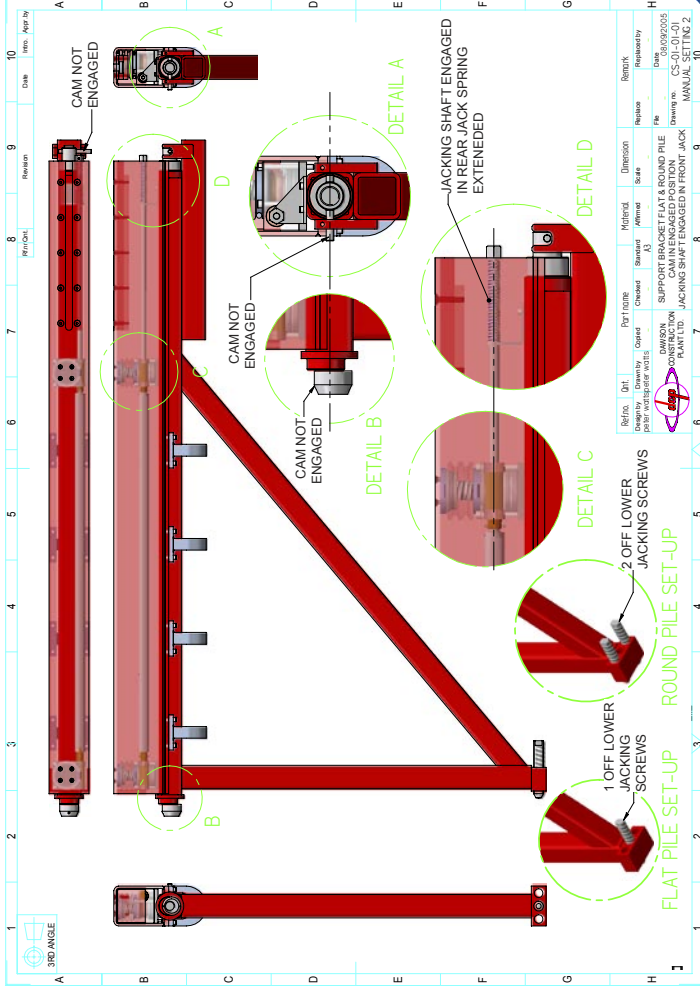

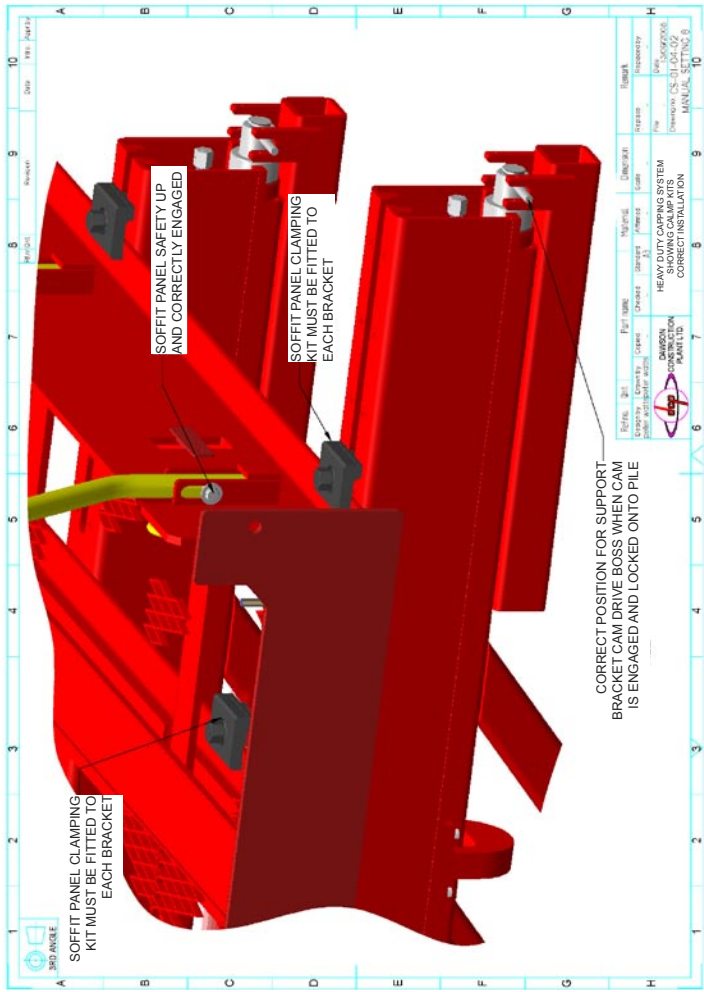

3RD ANGLE
SOFFIT PANEL CLAMPING KIT MUST BE FITTED TO EACH BRACKET

SOFFIT PANEL SAFETY UP AND CORRECTLY ENGAGED

SOFFIT PANEL CLAMPING KIT MUST BE FITTED TO EACH BRACKET

CORRECT POSITION FOR SUPPORT BRACKET CAM DRIVE BOSS WHEN CAM IS ENGAGED AND LOCKED ONTO PILE

Ref No.	3rd	Part name	Checked	Approved	Drawn by	Checked	Released	Issue	Remarks
Quantity	Quantity	Quantity	Quantity	Quantity	Quantity	Quantity	Quantity	Quantity	Quantity
Author	Author	Author	Author	Author	Author	Author	Author	Author	Author
 HEAVY DUTY CAPPING SYSTEM SHOWING CLAMP KITS CORRECT INSTALLATION MANUAL SETTING 6									



DAWSON
CONSTRUCTION PLANT LTD

SOFFIT SHUTTER PANEL

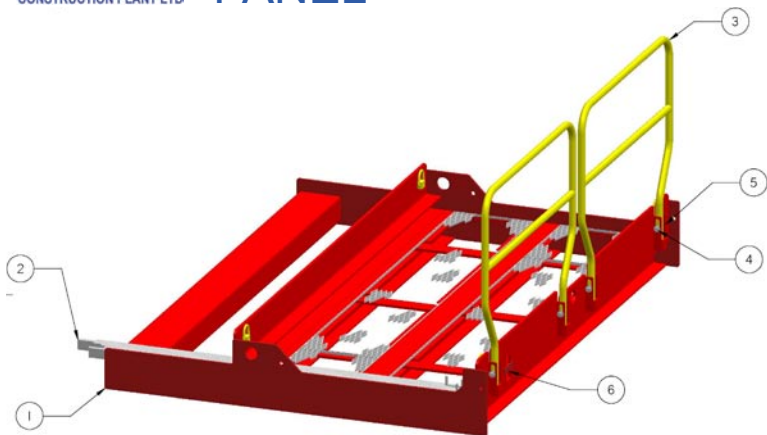

Reference	Qty	Part Name	Dimensions	Remark
6	1	Bar Retaining Plate	40x10x140	CS-01-18-01
5	8	Retaining Washer	Ø40	CS-01-14-01
4	4	Hand Rail Pivot Pin	Ø25	CS-01-13-01
3	2	Safety Hand Rail	See List	CS-01-10-01
2	148	Sliding Bar	See List	CS-01-06-03
1	1	Platform Fabrication	See List	CS-01-05-03

SUPPORT BRACKET

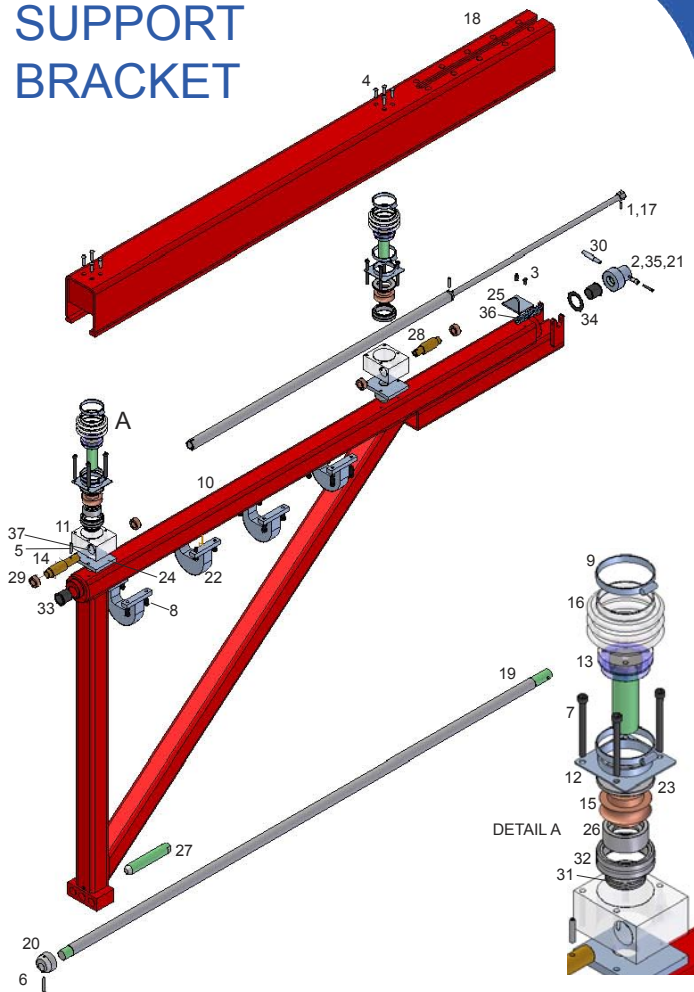

REF	QNT	PART NAME	DIMENSION	REMARK
37	2	Plug	RS 212-3385 (1 1/4)	CS-01-66-01
36	1	Compression Spring	Spring Steel	CS-01-65-01
35	1	Retaining Pin	Ø16x43mm	CS-01-50-01
34	1	Thrust Washer	Igus Thrust Washer	CS-01-46-01
33	2	Flanged Bush	Igus Bush	CS-01-45-01
32	2	Needle Roller Bearing	INA	CS-01-44-01
31	2	Axial Cylindrical Roller Bearing	INA	CS-01-43-01
30	1	Cam Drive Pin		CS-01-42-01
29	4	Bush		CS-01-41-01
28	1	Machined Worm Rear	SWE-4	CS-01-40-01
27	1	Lower Anchor Screw		M42 Thread Rolled
26	2	Bearing Support Sleeve		CS-01-38-01
25	1	Support Bracket		CS-01-37-01
24	2	Gearbox Mounting Plate		CS-01-36-01
23	2	Upper Bearing Guide		CS-01-35-01
22	4	Brace	See List	CS-01-33-01
21	1	Retaining End Collar		CS-01-32-01
20	1	Location Cam		CS-01-31-01
19	1	Cam Location Shaft	Ø45mm	CS-01-30-01
18	1	Leveling Top U Section	See List	CS-01-29-01
17	1	Height Adjusting Shaft	M42 Thread Rolled	CS-01-28-01
16	2	Gaiter		CS-01-26-01
15	2	Machined Worm Wheel	M3-25 Double Boss	CS-01-25-01
14	1	Machined Worm Front		CS-01-24-01
13	2	Jacking Screw Assembly	See List	CS-01-23-01
12	2	Gearbox Cover		CS-01-22-01
11	2	Gearbox Body		CS-01-21-01
10	1	Frame Fabrication Assembly		CS-01-20-01
9	4	Jubilee Hose Clip	Ø90-110	6-501-05-01
8	16	Socket Head Cap Screw	M12x40 LG	0M12-040-02
7	8	Socket Head Cap Screw	M10x110	0M10-110-02
6	1	M8 Coiled Spring Pin	Ø8x70	0M08-070-36
5	2	M8 Coiled Spring Pin	Ø8x45	0M08-045-36
4	8	Countersunk Socket Head Screw	M8x40	0M08-040-03
3	2	Socket Head Cap Screw	M8x20	0M08-020-02
2	1	Socket Head Cap Screw	M6x50	0M06-050-02
1	1	M6 Coiled Spring Pin	Ø6x30	0M06-030-36



DAWSON
CONSTRUCTION PLANT LTD

CLAMPING KIT

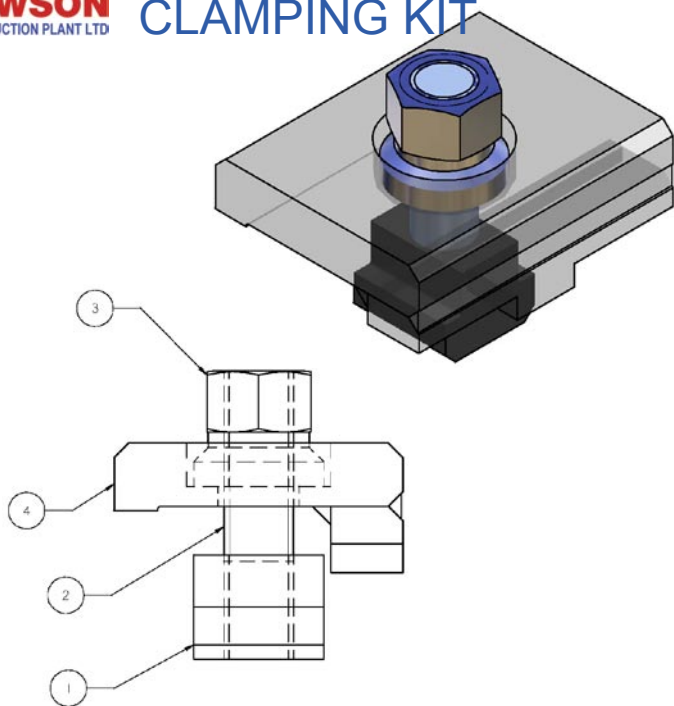

REF	QNT	PART NAME	MATERIAL	DIMENSION	REMARK
1	1	M24 T-Nut	070M20	WDS 644-208	CS-01-57-01
2	1	M24 x 100 Stud	Gr.606M36T	WDS 405-208-100	CS-01-58-01
3	1	M24 Swivel Nut	Gr.606M36T	WDS 408-206	CS-01-59-01
4	1	M24 Dovetail Clamp	-	-	CS-01-60-01



DAWSON
CONSTRUCTION PLANT LTD

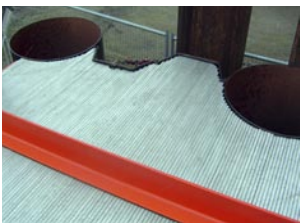



DAWSON
CONSTRUCTION PLANT LTD





DAWSON
CONSTRUCTION PLANT LTD

SHEET PILE CAPPING SYSTEMS

Dawson Construction Plant Ltd
Chesney Wold.
Bleak Hall,
Milton Keynes,
MK6 1NE, England
Tel: +44 (0) 1908 240300
Fax: +44 (0) 1908 240222



D.C.P. RESERVES THE RIGHT TO DISCONTINUE EQUIPMENT AT ANY TIME, OR CHANGE SPECIFICATIONS OR DESIGNS WITHOUT NOTICE OR INCURRING OBLIGATIONS

REV.SPSC01c