

PAJOT 2800 HAMMER

SPECIFICATIONS

Approx. weight (without guide)	2 800 kg
Approx. weight (with standard guide)	3 800 kg
Impact energy at 8 bars	1 600 kg.m
Blow rate	190 BPM
Air required flow rate	20 000 to 25 000 l./minute
Hose diameter	50 mm

This hammer can be fitted with :

- ▣▣▣ 1 rectangular anvil
- ▣▣▣ 1 square anvil
- ▣▣▣ Under water job set-up



FURTHER INFORMATIONS

Maximum practical load able to be exerted on a pile : 56 t.

Work capacity in an average ground :

- ▣▣▣ **Double sheet piles,**
15 meters in ground
- ▣▣▣ **Open tubes diam. 350 mm,**
15 meters in ground



PAJOT 2800 HAMMERS

EQUIPMENTS

Specials guides on request, contact us

Adjustable standard guide :

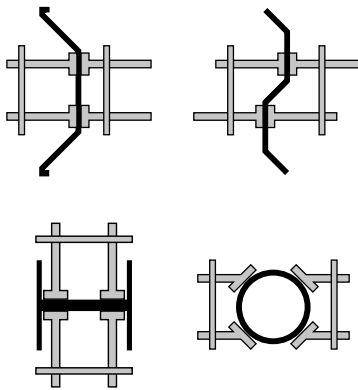

Adjustable standard

guide for small width sheet pile 600 mm and double sheet pile or H from 260 mm inside.

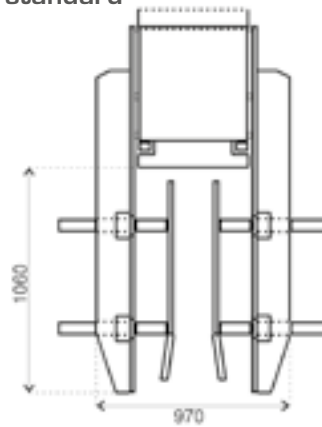

Standard pile guide for max 315 mm

New model adjustable from 100 to 370 mm

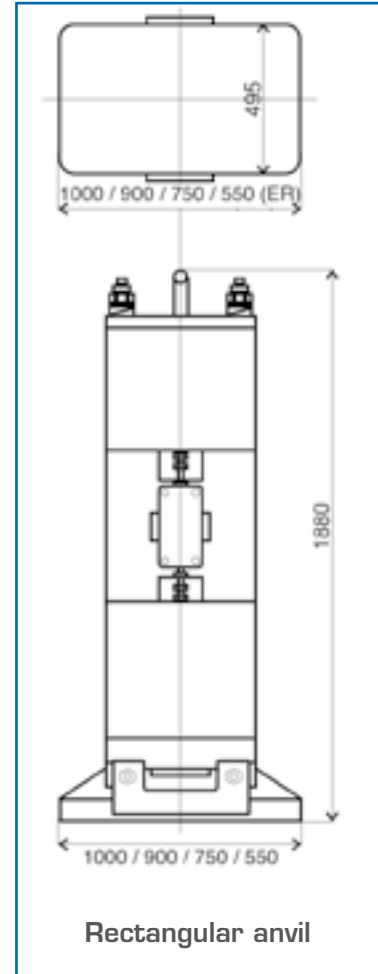
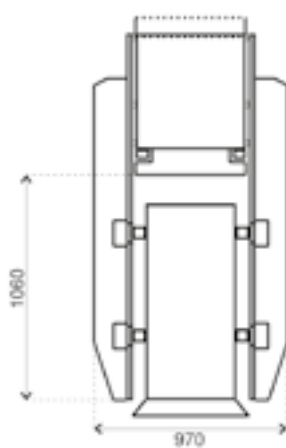

Rectangular anvil

New adjustable pile guide :

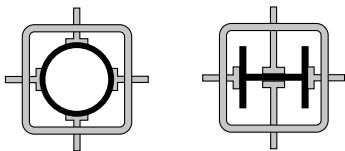

Noise abatement cover available for all hammers

