

PAJOT 600 HAMMER

SPECIFICATIONS

Approx. weight (without guide)	600 kg
Approx. weight (with standard guide)	850 kg
Impact energy at 8 bar	242 kg.m
Blow rate	300 BPM
Air required flow rate	7 000 l./minute
Hose diameter	40 mm

This hammer can be fitted with :

- ☑ 1 rectangular anvil
- ☑ 1 square anvil
- ☑ Under water job set-up



FURTHER INFORMATIONS

Maximum practical load able to be exerted on a pile : 9 t.

Work capacity in an average ground :

- ☑ 400 mm single **sheet pile**,
3 à 5 meters in ground
- ☑ **Pointing closed tubes** diam.
114 mm, 20 à 25 meters in ground
- ☑ **Open tubes** diam. 300 mm,
5 à 6 meters in ground





PAJOT 600 HAMMER

EQUIPMENTS

Specials guides on request, contact us

Adjustable standard guide :

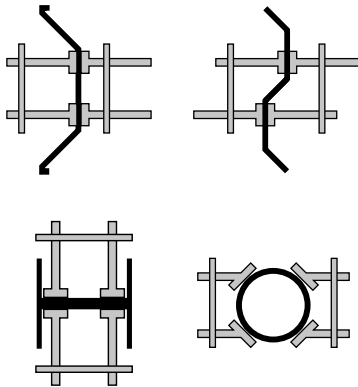

Adjustable standard guide for sheet piles or H from 240 mm inside

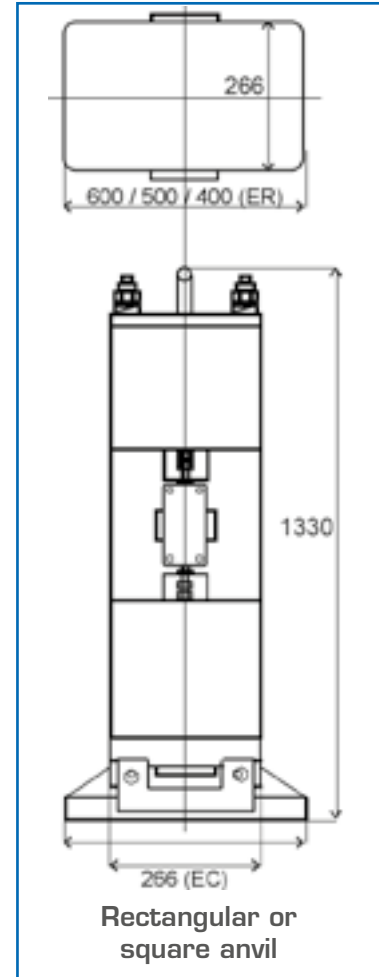
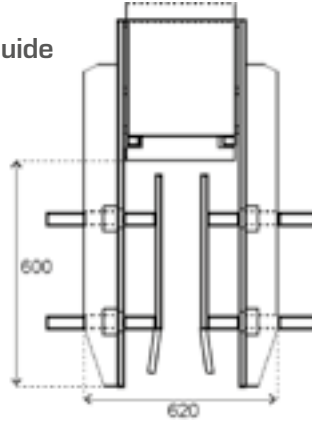

New adjustable pile guide :

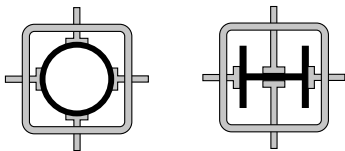

Standard pile guide for max 210 mm

New model adjustable from 100 to 260 mm

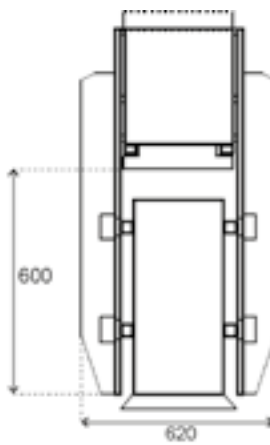

Noise abatement cover available for all hammers



